

## TCRT-LFSM-Analogue

### General Description

The TCRT-LFSM–Analogue sensor is used as a as a line sensor, but it can be used as a general-purpose proximity or reflectance sensor. The module consist of 5 IR emitter and receiver (phototransistor) pairs Each phototransistor. Theses high performance TCRT sensors IR LEDs emits IR light and phototransistor receive that IR light after reflection. TCRT gives out different analogue voltage for different color and distance.

TCRT provides day light blocking filter so erratic behaviour is avoided. The module is very compact and it gives analogue output. The power consumption is low for this module.

Range for output voltage depend on your input voltage. It is recommended to use sensor board on normal TTL power supply that is +5V supply.

### Pin Configuration

If you hold the sensor in your hand with notch of connector facing upward as shown in figure then your pins will be

Pin No.	Connection	Pin No.	Connection
1	GND	6	Sensor5
2	VCC	7	Sensor3
3	Sensor1	8	NC
4	Sensor4	9	VCC
5	Sensor2	10	GND

### Application Ideas

- Line sensing robots
- maze solving robot
- Position sensor for shaft encoder
- Detection of reflective material such as paper, IBM cards, magnetic tapes etc.
- General purpose - wherever the space is limited

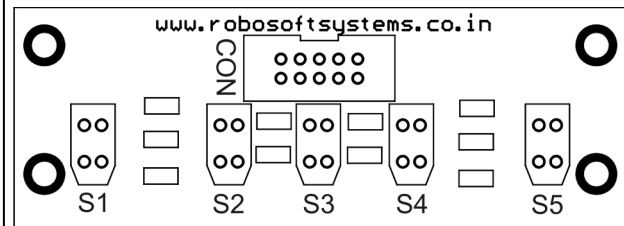

TCRT sensors Module Board

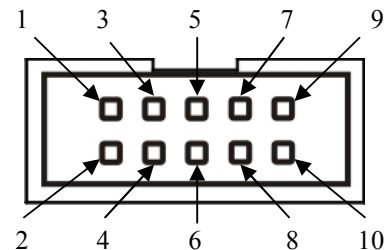

# TCRT/LSM/Digital

## Functional Block Diagram /Schematic Diagram

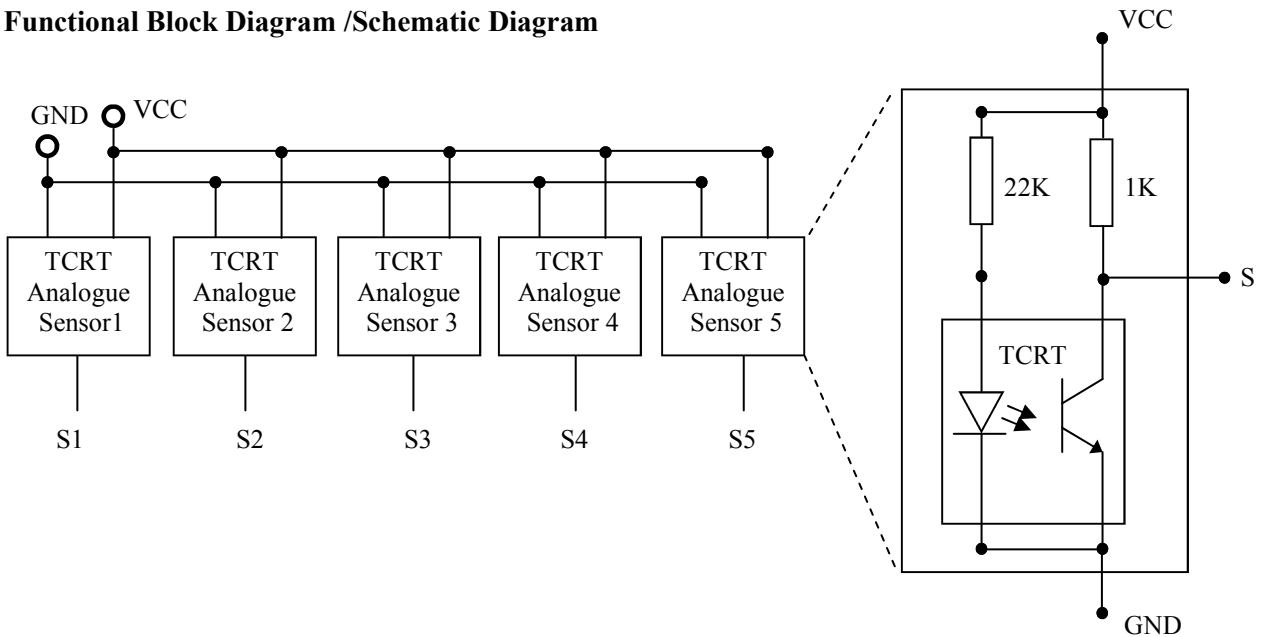

## Overview of Schematic

There are 5 TCRT sensors. Output of each sensor is given directly on module output pins. Each module consist of one IR LED and Photo Transistor pair.

The output of TCRT sensor dependent on distance from surface and reflective material type and its color.

## Maximum Ratings

Symbol	Quantity	Minimum	Typical	Maximum	Unit
$V_{DD}$	Operating Voltage	4.5	5	5.5	V
$V_{SS}$	Ground Reference voltage	-	0	-	V

## Pin Out Dimensions

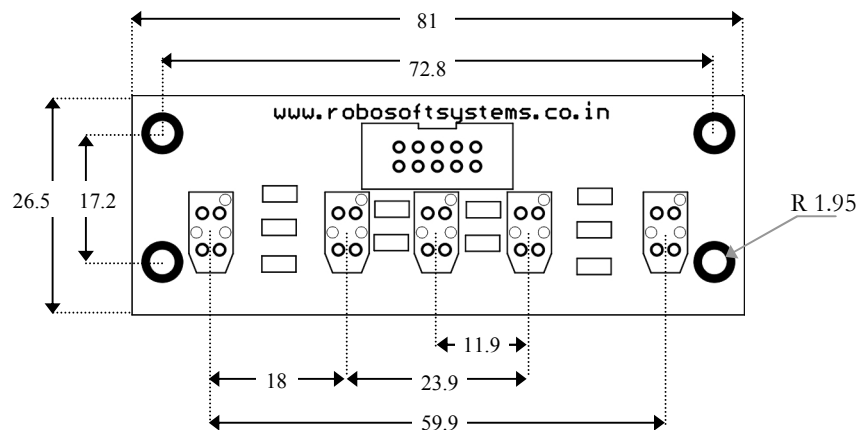

Note : All dimension in mm  
Error of  $\pm 5\%$  is subjected because of component soldering